

## Signal Consulting, LLC

16 Wilelinor Drive, Edgewater, MD 21037-1003 USA

Phone: 410-224-8429, Fax: 410-510-1821, E-mail: info@signalllc.com

### Si25NeTEPTC1-12B-20V-10A

## Networkable, **Low-Voltage**, Bidirectional, Thermo-Electric (TE), Proportional, **12-Bit**, Temperature Controller with RS232 Serial Port, Integrated Heat-Sink, and with LCD Port, PWM B-Chip

The **Si25NeTEPTC1-12B-20V-10A** is a 20V 10A, microprocessor based, closed-loop, Networkable, Thermo-Electric, Proportional, **12-Bit**, Temperature Controller board that heats or cools a thermal-zone. **The temperature is measured with a 12-bit digital sensor and proportionally controlled with 0.0625°C steps in the -25°C to +102°C range.** An efficient low voltage (3V to 20V DC) H-bridge controls the current (in the 0 to +/- 10A range) to a **Low-Voltage** type Peltier Thermo-Electric (TE) cell, functioning as a bidirectional heat-pump. **This H-bridge is specially designed to operate at low DC supply voltage levels (3V to 20V range) and fully turns on at 3V.** By proportional control, we mean that the amount of correction used in the closed-loop is proportional to the difference between the set and measured temperature values. Two user selectable proportional control grids **G8** or **G9** are used to control a wide range of thermal loads. Grid **G8** is used for small loads (typically: 10cm x 10cm x 10cm Aluminum block, **G8** is selected when **C5** is installed) and **G9** is used for large loads (selected when **C5** is open). Each control grid consists of sixteen non-uniformly spaced temperature levels (centered at the set-temperature value) with eight PWM duty-cycle values are used to control the temperature in 0.0625°C steps. **The temperature overshoots and oscillations ("hunting") are limited to approximately + or - 0.5°C.** The temperature is sampled at approximately 1Hz rate and the control-loop/display is updated with the same rate. An onboard microprocessor measures and controls the temperature; monitors the user inputs; and drives the LCD. A small 12-bit digital thermometer, Signal's part number **Si24DTsens-12B** (connected to port **CN3** and uses the Dallas Semi., DS18B20 sensor) is used to measure and control the temperature in the -25°C to +102°C range, with ½°C accuracy. Because this sensor is digital, it is virtually immune to noise and loading; ideally suited for remote sensing. This sensor uses a unique "1-wire interface" (with parasite power mode) that requires only 2-conductors for reliable remote (typical length of 20 meters) temperature sensing. As the name (**Ne, Networkable**) implies, the desired set-temperature is selectable -25°C to +102°C range, with 0.1°C steps; using ASCII command strings, obtained from the RS232 Network Port, **CN6**; or it can be changed by using external **UP/DOWN keys** connected to **NC4**. The RS232 data format and the Local Area Network (LAN) commands are described on the next page. A "Kill-Switch" (connected to **J1**) is used for emergency TE-off (switch open=TE-Cell on, Switch closed=TE-Cell off with zero current, as shown on the application drawing below). An optional LCD port (with RS232 Standard) is provided for display of the Set and Measured temperature data. The 2 line x 16 character LCD can be ordered from Signal under the part number of **Si14LCD2L16CH** (with 12" cable and 4-pin connectors and with back-light). A bicolor LED is used to monitor the TE cell (or load) voltage (Red = Heat, Green = Cold). This board operates with a two unregulated voltage sources; the bridge requires a 3V to 20V DC source (connected between -P to +P terminals), while microprocessor requires a 9V to 30V DC source (connected between -P to +C terminals). A small (4.0"x3.3"x0.062"), integrated, Aluminum heat-sink plate is used to operate at 200W power level. Higher power-levels can be achieved with more efficient heat-sinks. Typical applications are: Peltier Effect TE Coolers, Heat Pumps, etc.



### Specification and Application of **Si25NeTEPTC1-12B-20V-10A**

- **Typical Operating Temperature at 20A:** 35°C with the Metal Heat-Ring Bolted to a small (4.0"x3.3"x0.062") Aluminum Heat-Sink Plate, while it is exposed to ambient air at 25°C (as shown on photograph).

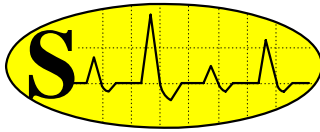

# Signal Consulting, LLC

16 Wilelinor Drive, Edgewater, MD 21037-1003 USA

Phone: 410-224-8429, Fax: 410-510-1821, E-mail: info@signallc.com

- **Source-Voltage Requirements:**  $V_C$  (from pin +C to pin - P): 9V to 30V DC, and for  $V_P$  (from pin +P to pin -P) 3V to 20V, both unregulated DC voltages. For high-voltage applications (9V to 20V) a single DC power supply can be used by connecting pin +P and pin +C together.
- **Average Load Current of  $i_L(t)$ :** 0A at 0% Duty-Cycle and 10A max. at 100% Duty-Cycle.
- **Load Isolation:** The Load or TE cell must be isolated from the source voltage ( $V_P$ ).
- **Power-Conversion Efficiency:** Approximately 98.5% at full-load (20V and 10A).
- **Set-Temperature** is adjustable from  $-25^{\circ}\text{C}$  to  $+102^{\circ}\text{C}$ , in  $0.1^{\circ}\text{C}$  steps; with network commands.
- **Measured-Temperature** is determined in the  $-25^{\circ}\text{C}$  to  $+102^{\circ}\text{C}$  range, with  $\frac{1}{2}^{\circ}\text{C}$  accuracy, and with  $0.0625^{\circ}\text{C}$  precision; using the Dallas Semi. DS18B20 (in TO-92 casing) Digital Thermometer.
- **Two User Selectable Proportional Temperature Control Grids G8 or G9 are Used:** Grid G8 is used for small thermal loads (selected when J2 is installed) and G9 is used for large loads (selected when J2 is open). Each control grid uses sixteen non-uniformly spaced temperature levels with eight PWM duty-cycle values, controlling the temperature with  $0.0625^{\circ}\text{C}$  steps. The temperature overshoots and oscillations (“hunting”) are limited to approximately + or -  $0.5^{\circ}\text{C}$ .
- **Sampling Rate:** The temperature is sampled at approximately 1Hz rate and the control-loop/display is updated with this same rate.
- **Load-Current Indicator and Protection:** An onboard bicolor LED is used to monitor the TE cell (or load) voltage (red = heat, green = cold). The analog control inputs are zener-diode protected.

## A Typical Application of the Si25NeTEPTC1-12B-20V-10A

In this 12-bit, closed-loop, proportional temperature control application, the Set-Temperature is adjusted by command strings derived from a Personal Computer (PC) using the Microsoft “Hyper Terminal” program (or any other ASCII controller) operating at 9600 Baud, 1 start-bit, 8 data-bits, 1 stop-bit, No parity-bit. The Peltier type Thermo-Electric (TE) cell is functioning as a bidirectional heat-pump; operating with 3VDC (unregulated) at 10A max. The [Low-Voltage TE cells](#) can be purchased from [TE Technology, Inc.](#) WEB: [www.tetech.com](#). The temperature of the enclosed and insulated Hot/Cold Environment is measured with the Dallas Semi. DS18B20 (in TO-92 casing) Digital Thermometer, [Si24DTsens-Spec1-DS18B20](#). This sensor can be purchased from Signal Consulting, LLC as [Si24DTsens-12B](#) (DS18B20 with 12” leads and connector). The optional LCD module can be ordered from Signal using the part number of [Si14LCD2L16CH](#) (2x16 display with 16” cable and 4-pin connectors, and with back-light). **Warning: The connecting wires to the Load and the Power Supply must be heavy gage copper wire (#12 AWG or heavier) to handle the rated current level. In addition, these heavy gage wires act as a heat sink, protecting the board from overheating.**

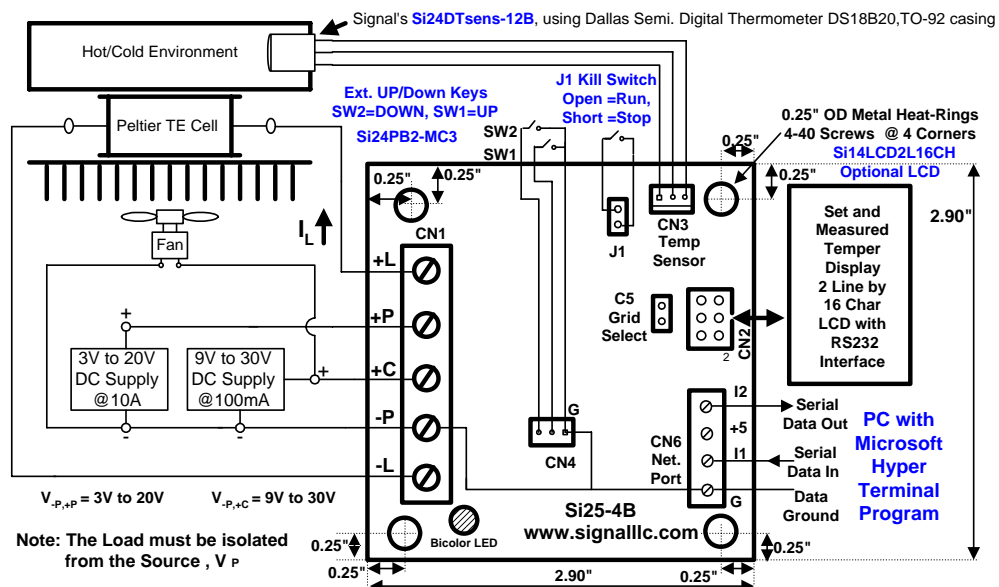

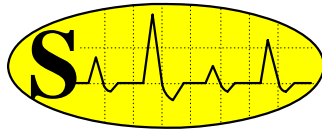

# Signal Consulting, LLC

16 Wilelinor Drive, Edgewater, MD 21037-1003 USA

Phone: 410-224-8429, Fax: 410-510-1821, E-mail: info@signalllc.com

## Command Format and Local Area Network (LAN) for the [Si25NeTEPTC1-20V-10A](#)

Each board has a unique, 8-bit, ASCII, **none-volatile**, Node-Address ranging from 1....9, A..Z, a,...z (or a total of 61 Units can be networked). The address can be changed by a **LAN** command (the factory default address is 1). The board uses a modified version of the RS232 serial-data communication standard, where the output-voltage (on pin **I2**, **CN6**) ranges from 0 to +5V (rather than the usual -12V to +12V). In addition, this output pin is normally an open circuit and it will only output a serial TTL binary bit-stream when properly referenced by its Node-Address. The serial data input-voltage (on pin **I1**, **CN6**) has the standard range of -12V to +12V. The serial data-format is: 9600 Baud Rate, 1 Start-Bit, 8 Data-Bits, 1 Stop-Bit, and no Parity-Bit.

These features allow the creation of a Local Area Network (**LAN**) with up to 61 nodes (boards). A typical 3-wire **LAN** with "Star Topology" is shown below. Note that the control lines (**G**, **I1**, **I2**) with the same name are connected together (or the boards are connected in parallel) and driven by an **ASCII** controller (or **PC**), equipped with an RS232 serial port, operating at 9600 Baud rate.

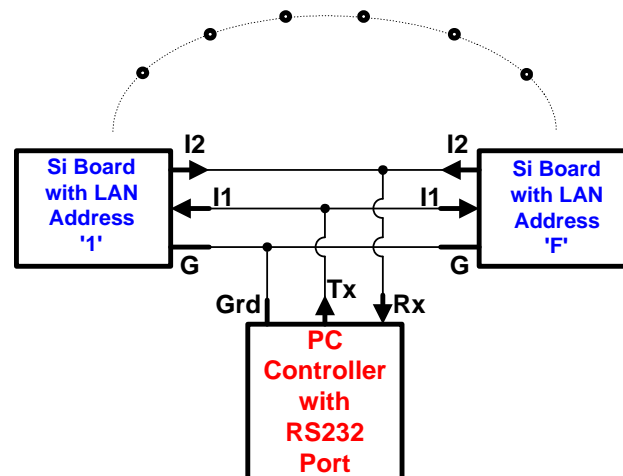

### Command Rules:

1. All Commands are **ASCII** character strings (Chars.). An ASCII string is denoted here with **Bold Red Letters (Characters)**.
2. Each string is terminated by a Carriage Return Character, **(CR)**. The only exception is the **#** command.
3. Upper-Case Letters are used for Output Commands; and Lower-Case Letters are used for Input Commands.
4. The 1<sup>st</sup> Char. in a string is either ASCII **#** or a Node Address (**1, .,9,A..Z, a,...z**). If the 1<sup>st</sup> Char. is an **#**, it denotes a query to all boards on the LAN to output their Node Address and Program Name.
5. If the 1<sup>st</sup> Char. is an ASCII (**1,..9, A,..Z, a,...z**), it directs the rest of the command string to the board that has this address.
6. The 2<sup>nd</sup> Char. in the string is the Command Character that operates on the addressed board.

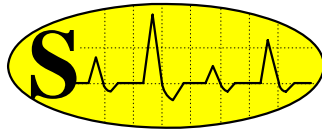

# Signal Consulting, LLC

16 Wilelinor Drive, Edgewater, MD 21037-1003 USA

Phone: 410-224-8429, Fax: 410-510-1821, E-mail: info@signalllc.com

7. The 3<sup>rd</sup>, 4<sup>th</sup>, 5<sup>th</sup> and 6<sup>th</sup> Chars. represents the value of the input data. Where + denotes positive Set-Temperature values; and - denotes negative Set-Temperature values.

8. The last Char. in the sequence is always the string terminator, **(CR)**.

## Command Examples on Input Line I1:

Ex#1. Com. String: **#** Action: All boards on the LAN will output their Address and Program Name.

Ex#2. Com. String: **1u5(CR)** Action: Change Board 1 Address in EPROM from 1 to 5.

Ex#3. Com. String: **1T(CR)** Action: Board 1 outputs its Set and Measured Temperature.

Ex#4. Com. String: **2t25(CR)** Action: Change Board 2 Set-Temperature to +25.0C.

Ex#5. Com. String: **2t+25.0(CR)** Action: Change Board 2 Set-Temperature to +25.0C.

Ex#6. Com. String: **2t-25(CR)** Action: Change Board 2 Set-Temperature to -25.0C.

Ex#7. Com. String: **2t-25.0(CR)** Action: Change Board 2 Set-Temperature to -25.0C.

**We recommend that you use approximately 25msec (or longer) delays between characters when inputting a command string ("1t..(CR)" or "1T(CR)") to this controller board.**

Occasionally, a transient character may be captured and buffered by one more board on the LAN, this **transient character can be cleared by sending one or more (CR) prior to a valid command string.**

## Response to Commands on Output Line I2:

The response to the "**1T(CR)**" command is an ASCII character string (or a line of characters). Each string is terminated with carriage return and line feed characters. An example is shown below:

**N=1 ST=+025.00 C MT=+023.87 C**

Note that there are two space characters between **1** and **S**; and there are two space characters between **C** and **M**. The length of this character string is 33, including carriage return and line feed characters (not shown in this example).

Where **N=1** is the node (or unit) address of the board (can be changed with the **u** command), **ST=+025.00 C** is the last Set-Temperature in degree Centigrade (entered with the **t** command), and **MT=+023.87 C** is the current Measured-Temperature in degree Centigrade.

Each character string (line) is a continuous stream of ASCII characters with an occasional pause (or delay) between characters. This delay is approximately 1msec.

**The on-board microprocessor provides the bus arbitration, required to avoid data collisions on the 3-wire LAN bus.**

## Network Configuration:

The **Si..Ne..** boards can be arranged in many Local Area Network (LAN) topologies: Star, Daisy-Chain, etc. You may create your own network or you may order one or more of the Network Cable Assemblies listed in the Application Note. **Before you build a network, we recommend that you click on this blue link and read this Application Note: [SigNote on Configuring a LAN-2](#) .**