

# Signal Consulting, LLC

16 Wilelinor Drive, Edgewater, MD 21037-1003, USA

Phone: 410-224-8429, Fax: 410-510-1821, E-mail: info@signallc.com

## Model Si20HPB4-50V-32A

### 50V-32A High Power H-Bridge Board for Bi-directional DC Motor Control with an Integrated 15W Finned Heat Sink

#### Si20HPB4-50V-32A Features:

- Pulse-Width Modulation (PWM from 0-20 kHz) for Bi-directional Speed Control.
- Four HexMOSFETs with a 15W integrated finned heat sink for 9V to 50V DC Motors (or any Load).
- Max. Continuous Load (or Motor) Current: +/- 32 A at 60 Hz PWM, and +/- 2 A at 20 kHz PWM.
- Max. Surge Load (or Motor) Current for 2 seconds: +/- 80 A at 60Hz PWM, +/- 15 A at 20 kHz PWM.
- The PWM Control Lines are Optically Isolated from the Motor-Power Circuits.
- 100% Solid-State Components (no relays).
- 0 to 5 V (TTL) for Control-Voltage Inputs, with 0 to 100% duty-cycle variation for PWM.
- A bicolor LED is used to monitor the load voltage or motor direction (Forward = Red, Reverse = Green).

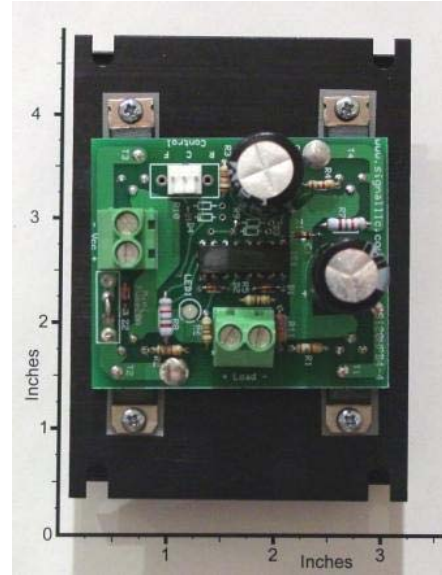

The **Si20HPB4-50V-32A** is an efficient high-power H bridge that works over a wide range of source voltages (9V to 50V) at high continuous load currents (+/-32A max). This board includes a 15W aluminum heat-sink with fins (3.0"x 4.5"x0.8", as shown) to achieve this impressive performance. Higher current values can be attained with more efficient heat sinks. The motor action (as shown below) is controlled by the voltages applied to pin **F** and pin **R** (relative to pin **C**) on the **Control** connector. **These pins are optically isolated from the rest of the power circuit.**

#### Control Input Truth Table (for Control connector)

$V_{FC}$ (voltage on pin F relative to pin C )	$V_{RC}$ (voltage on pin R relative to pin C )	Motor / Load Action
$V_{FC} = 0V$ or open	$V_{RC} = 0V$ or open	Motor Stop / Load Current OFF
$V_{FC} = 5-7V @5mA$	$V_{RC} = 0V$ or open	Motor Forward / + Load Current
$V_{FC} = 0V$ or open	$V_{RC} = 5-7V @5mA$	Motor Reverse / - Load Current
$V_{FC} = 5-7V @5mA$	$V_{RC} = 5-7V @5mA$	Not Recommended *

\* When  $V_{FC}$  and  $V_{RC}$  are HIGH at the same time, the motor rotation will be forward or reverse depending which signal arrives to HIGH state first. But no damage will occur to the Load (Motor) or to the power electronics.



# Signal Consulting, LLC

16 Wilelinor Drive, Edgewater, MD 21037-1003, USA

Phone: 410-224-8429, Fax: 410-510-1821, E-mail: info@signalllc.com

- The  $V_{RC}$  and  $V_{FC}$  control lines can be Pulse-Width Modulated (PWM in a range of 0-20k HZ) to vary the average current supplied to a load or to a DC Motor.

### About the Voltage Requirement:

Most DC motor drivers will operate at only one voltage level (12 V, 24 V or 48 V). That means, if the motor is changed from 12 V to 24 V, a new driver must be purchased. This is not true for this driver. The Si20HPB4 will work with any DC motor in the 9 V to 48 V range. In addition, the power filters are included on this board. Consequently, only unfiltered (full-wave rectified) DC input power is required. Furthermore, the control circuit is optically isolated from the power circuit; rejecting unwanted power glitches.

### A Typical Motor Control Application of the **Si20HPB4-50V-32A**

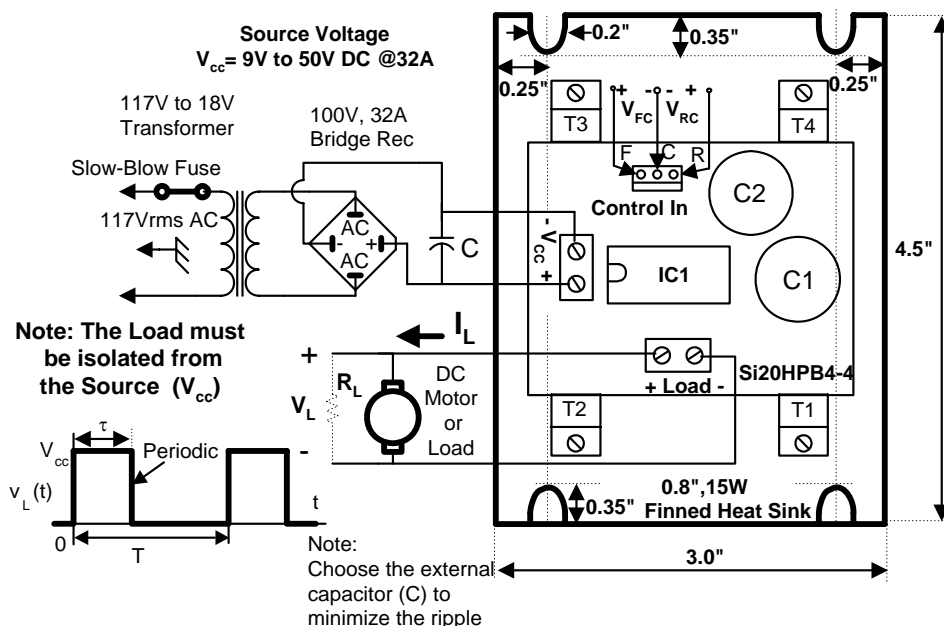

**Warning: The connecting wires to the Load and the Power Supply must be heavy gage copper wire (#12 AWG or heavier) to handle the rated current level. In addition, these heavy gage wires act as a heat sink, protecting the board from overheating.**

### PWM Carrier-Frequency

The  $V_{RC}$  and  $V_{FC}$  control lines can be Pulse-Width Modulated (PWM with a duty-cycle of 0% to 100%) over a wide range of carrier frequencies, as shown on the graph. This plot was obtained with the 15W finned heat-sink (4.5" x 3.0" x 0.8", as shipped with the unit). Improved performance can be achieved with more effective heat-sinks.

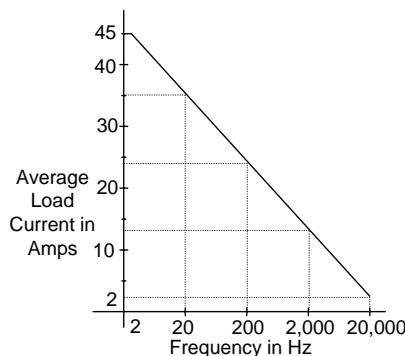

### Typical Applications:

Driver for Variable-Speed Bi-directional DC Motors, Peltier Effect TE Cells, Heat Pumps, PPDT Solid State Relays.